



Metal Detector

資正金屬檢出機



COMPUNIC

For Food & Pharmacy Industries

DETECT ALL METALS:

AL · CU · NI · Stainless · Iron · Non-Ferrous....



Innovative design , Progressive applications

- ◎ Slide-down Channel surpassed the traditional conveying belt platforms in testing products with sticky and oily properties which is difficult to test.
- ◎ Reduces maintenance cost, save time and money.
- ◎ User-friendly functionality and easy to clean compared to traditional conveying belt platforms.
- ◎ Easy to disassemble and assemble accessories.
- ◎ Reject device can be turned down forward fast and precisely exclude contaminated products.
- ◎ High sensitivity performance can detect fragment of metal or non-metal objects.
- ◎ Widely use in different area of food production, raw materials and before packing products.

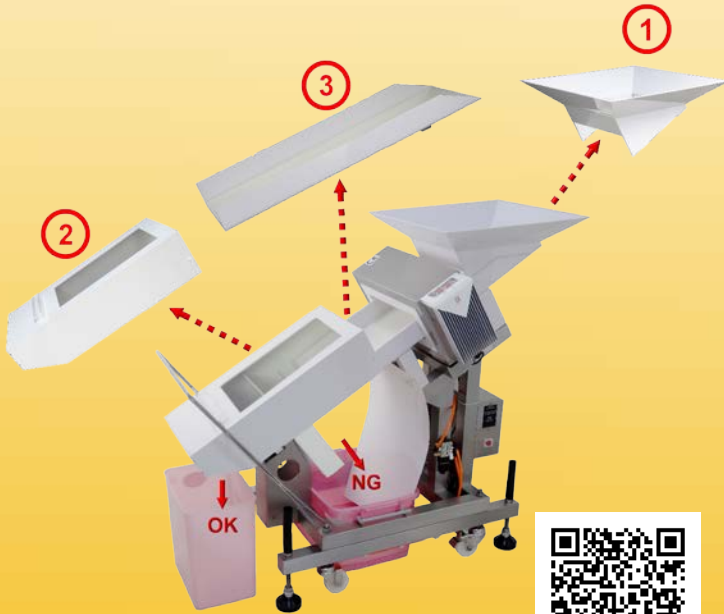

MD3010 Slide-Down Channel



MD6210 Slide-Down Channel



Testable Product Characteristics:



Snacks



Frozen vegetables



Meat Balls



Nuts

MD3010 Slide-Down Channel

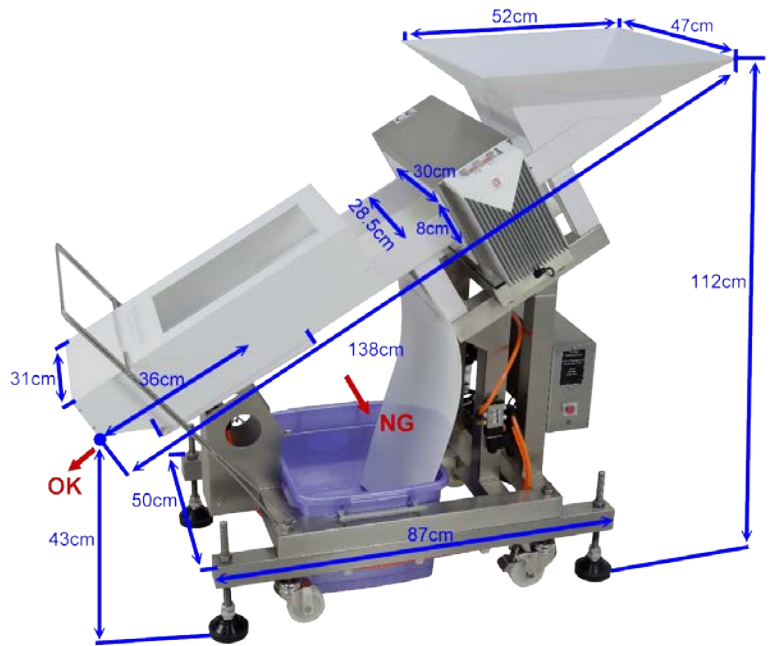
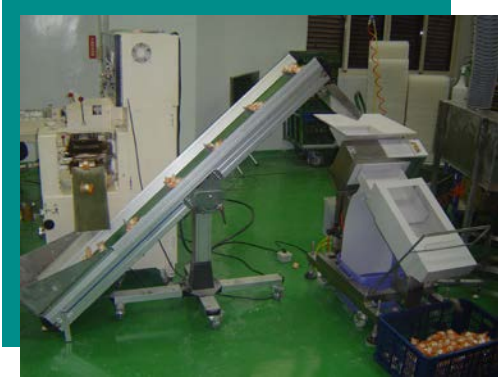

MD 3010 BRIEF SPECS 簡易規格說明

Aperture	FE	CU	SUS
30 x 10 cm	φ 0.7mm	φ 1.0mm	φ 1.5mm

MD6210 Slide-Down Channel

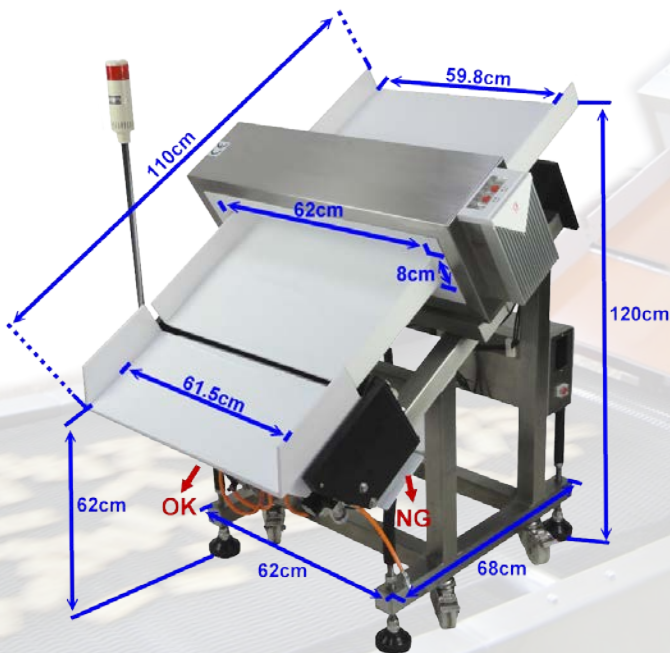

MD 6210 BRIEF SPECS 簡易規格說明

Aperture	FE	CU	SUS
62 x 10 cm	φ 0.8mm	φ 1.2mm	φ 1.8mm



資正電子企業股份有限公司

新北市新莊區五權一路 1 號 7 樓之 9 (五股工業區)

Tel: 886 2 22992533 Fax: 886 2 22992415

台中分公司:886-4-23503230

高雄分公司:886-7-3425586

COMPUNIC ELECTRONICS CO., LTD

7TH Fl.9 No. 1, Wu-Chuan 1 Rd., Hsinchuang Dist., New Taipei City, 24892 Taiwan

<http://www.compunic.com.tw>

EMAIL: compunic@ms1.hinet.net

Tel: 886 2 22992533 Fax: 886 2 22992415